

INDUX Heat Recovery Ventilation Unit

Through Wall Mounted

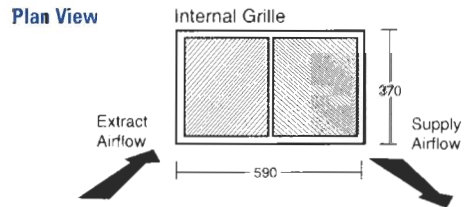

- Parts List**
- 1 Inner case with fans
 - 2 Outer case
 - 3 Outer grille
 - 4 Two outer grille screw and washer assemblies
 - 5 Divider board
 - 6 Heat exchanger
 - 7 Inner grille complete with filters
 - 8 Galvanised lintel

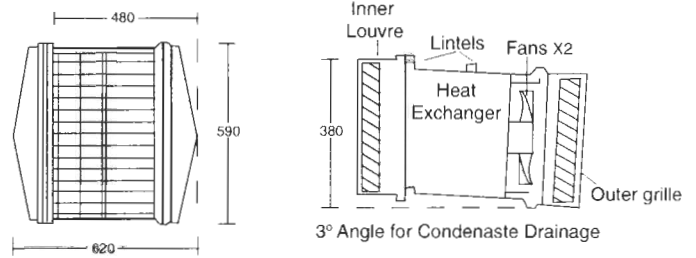
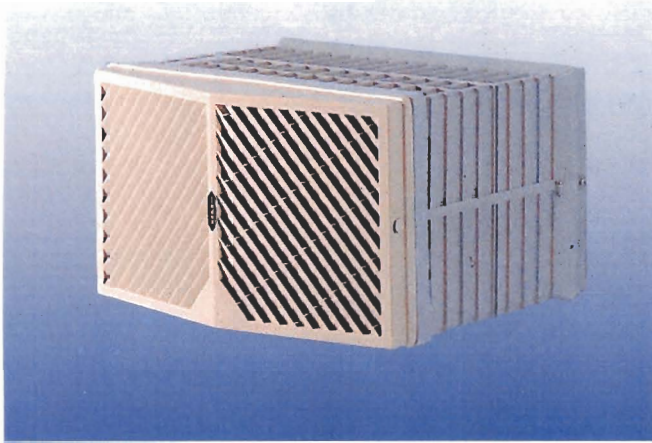
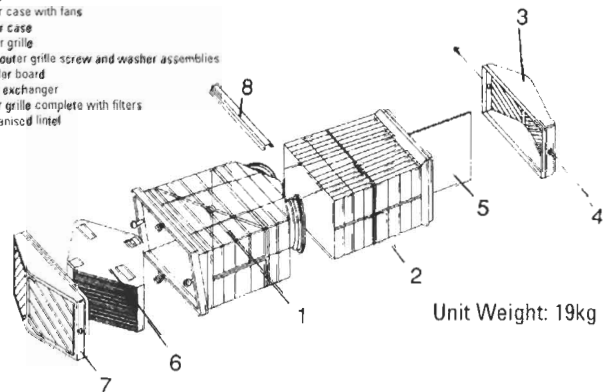

Unit Weight: 19kg

- Up to 70% heat transfer
- Light weight polymeric heat exchanger for easy cleaning
- Automatic condensate drainage clear of external wall
- Balanced supply and extraction or extraction only operation
- Integral washable filters for both extract and supply air
- Tough plastic construction
- 550m³/hr balanced supply and extraction and 900m³/hr extraction only

Applications

The IND 1 unit provides balanced ventilation for commercial and residential areas and is ideal for swimming pool, computer rooms, shower rooms and changing areas etc where avoiding cold draughts and maintaining internal temperatures is essential. Fresh pre-warmed air from outside is continually provided to the room with simultaneous extraction of stale air, odours and pollution. Filters are incorporated in the unit for both supply and extract air flows. Heat is transferred

from outgoing air to the fresh air supply with zero cross contamination, maintaining internal temperatures and providing a clean fresh working environment.

Performance

A compatible 3 speed controller type VCON 33 is recommended for use with this unit to provide variable speed operation at low noise levels. The controller also provides the facility to reverse the supply fan to achieve extraction only through the unit. On / Off speed selection and fan reversal can be automatically controlled using simple sensors.

A separate humistat can be used in conjunction with this equipment offering further flexibility.

Typical Installations

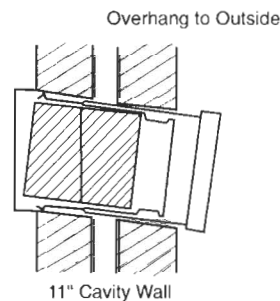

Air Volumes m³/hr

Heat Recovery Mode	Supply	Extract	Extract only
Speed 1	320	350	600
Speed 2	410	450	750
Boost	500	500	900

Electrical

- Supply Fan: 32 Watts
- Extract Fan: 105 Watts
- Wiring: 4 core and earth 1.0 - 1.5mm² cable
- Consumption: 0.63 amps continuous (1.3 amps start)

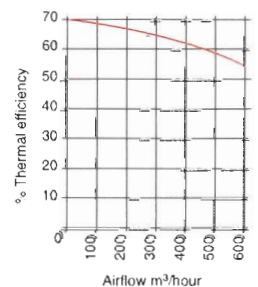

Heat Exchanger Efficiency